

**EN** >>

# Contents

---

## USE

Main Components -----	02
Descriptions of Functions and Parameters -----	03
Precautions -----	04
How to use PLUS FAN -----	05

## Installation

Overall Dimensions -----	10
Packing List -----	11
Mounting of PLUS Fan -----	13

## Others

Warranty regulations -----	19
Warranty card -----	20

- Thank you for choosing our product! Please read through this Manual before mounting and keep it properly for further reference.



# Main Components

## PLUS FAN

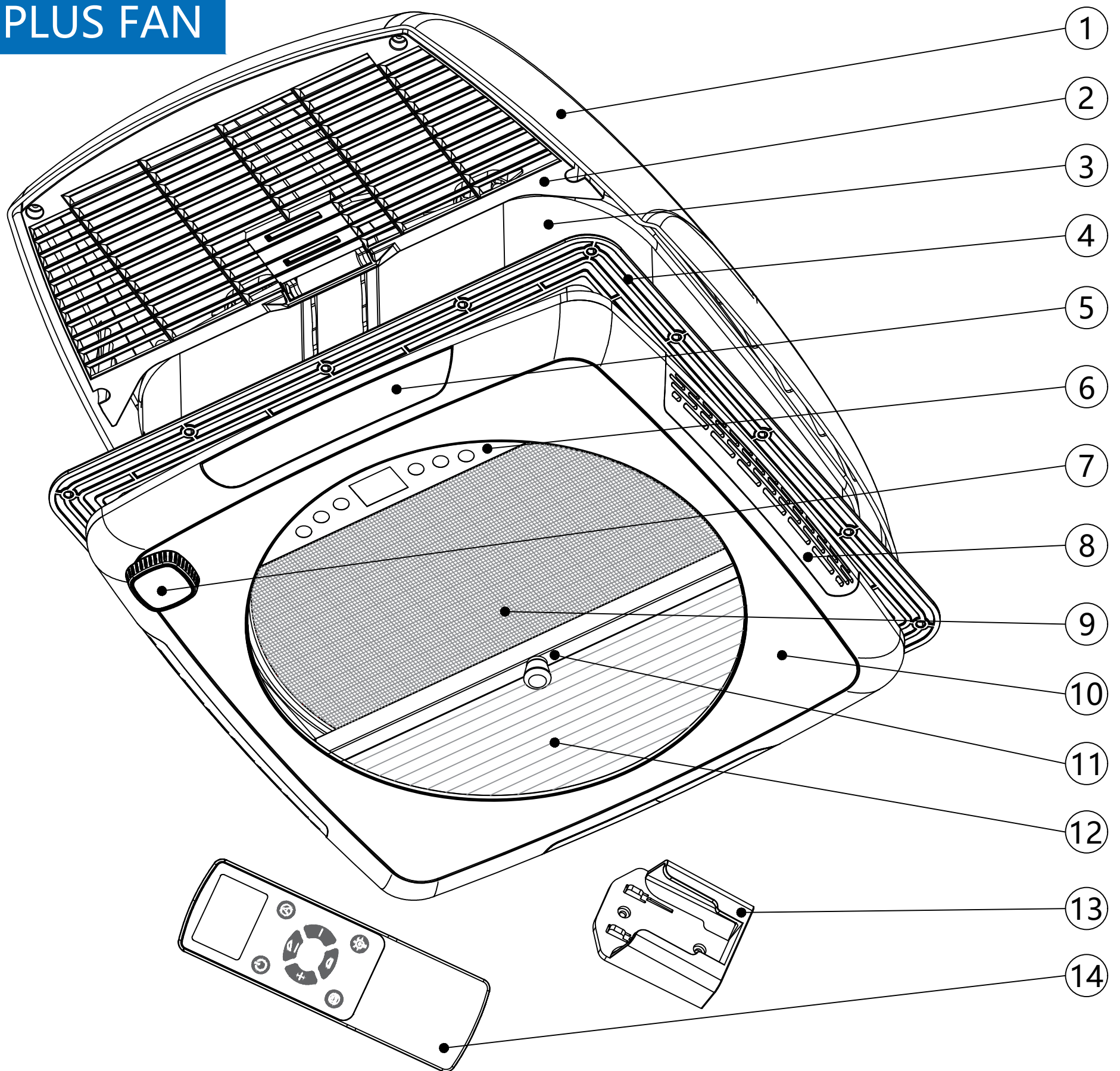

- |                     |  |                       |
|---------------------|--|-----------------------|
| ① Top cover         | ⑥ Control panel                              | ⑪ Push rod            |
| ② Outer grid        | ⑦ Hand knob                                  | ⑫ Pleated shade cloth |
| ③ Mounting frame    | ⑧ Interior trim frame                        | ⑬ Remote control base |
| ④ Body fixing plate | ⑨ Inner strainer                             | ⑭ Remote control      |
| ⑤ Lampshade         | ⑩ Decorative sticker for interior trim frame |                       |

# Descriptions of Functions and Parameters

<b>Safety Protection Function</b>	
Fan blade anti-pinch function	In case of any abnormal resistance when the the fan blade of PLUS FAN is rotating, the fan blade will stop after being blocked, and cannot work normally until its rotation is confirmed normal;
Top cover anti-pinch function	In case of any abnormal resistance during the lifting and lowering of the top cover of PLUS FAN, the top cover will stop immediately and cannot work normally until problem is removed.
Voltage protection	When the input voltage of the PLUS FAN ventilating fan is smaller than 9V or higher than 16V, the PLUS FAN ventilating fan does not work and is under voltage protection to prevent the vehicle battery from feedback or the PLUS FAN ventilating fan from being damaged;





<b>Performance Parameters</b>	
Opening size	355mm × 355mm / 400mm x 400mm
Thickness of mounting wall	27-80mm
Power	Full load power: 20W+4W (max. wind speed and full lighting)
Voltage	Normal voltage: 12V, working voltage: 9-16V (PLUS FAN does not work when the voltage is smaller than 9V or greater than 16V)
Current	Gear 4 by default: ≤0.25A, full-load maximum current ≤1.6A, locked-rotor maximum current ≤2.0A
Working noise	Air outlet noise of Gear 4 by default of PLUS FAN ≤ 29dB, air inlet noise ≤32dB; Air outlet noise of Gear 10 ≤47dB, air inlet noise ≤53dB;
Max. ventilation	Max. ventilation: 3,000 m <sup>3</sup> /min
IP rating	IP rating: IPX4
Temperature adjustment in AUTO mode	Default temperature of control panel: 26°C (non-adjustable); range of adjustable temperature in remote control: -2°C~40°C

# Precautions

Please read through this Manual before mounting, and install the casement window in strict accordance with the provisions contained in this Manual. In addition, keep this Manual properly for further reference.

To avoid any personal injury or property loss of users and third parties, please observe the safety warnings and precautions contained herein strictly.

- Marks and meanings

	Warning! Failure to abide by the requirements may lead to serious injury or damage.
	Caution! Failure to abide by the requirements may lead to damage.
	Operation is prohibited.
	Relevant information shall be noted.

## Warning!







1. Please ask a professional to install the casement window;
2. The manufacturer is not held liable for any damage of the casement window by external force or arbitrary without the explicit permission of the manufacturer;
3. Open the top cover of the PLUS FAN when driving. Please pay attention to the driving height; otherwise the top cover may be damaged when driving;
4. The PLUS FAN must be connected to a power supply of "DC12V, max. 5A" . Do not connect it with other power supplies (e.g.: DC24V, alternating current, etc.);
5. When connecting power supply with PLUS FAN, please confirm "+" (anode) and "-" (cathode) correctly. The red wire is "+" while the black wire is "-" .

## Caution!

1. In case of failure, power off and restart the ventilating fan and reset the fan's parameters. If fault still exists after the measures above, please consult the dealer immediately;
2. Please pay attention to the height limit on road when the top cover is opened during driving, so as to avoid damaging the top cover after collision;
3. Please pay attention to the weather conditions when opening the top cover of the ventilating fan while driving. Do not open the top cover in strong wind or heavy rain;
4. When manually closing/opening the top cover, please turn the handle to completely close/open the top cover. Do not turn the handle again after completely closing/opening, so as to avoid damaging the manual function of the ventilation fan.







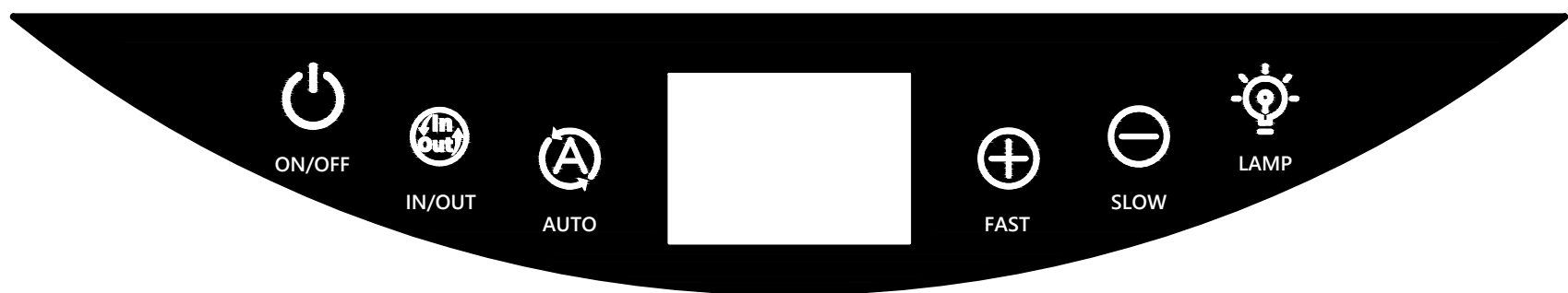

# How to Use PLUS FAN

## Control panel

Touch icons	 ON/OFF	 IN/OUT	 AUTO	 FAST	 SLOW	 LAMP
Corresponding	Power	In or Out	AUTO	FAST	SLOW	LAMP



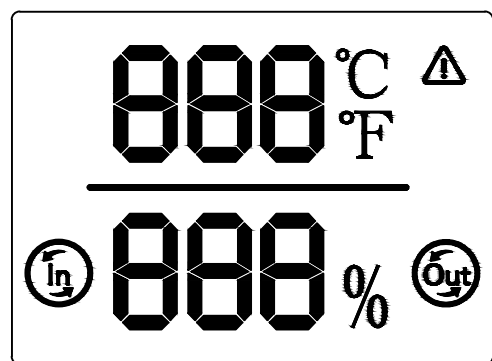

Control Panel

Display icons					
Function	Current indoor temperature	IN/OUT	FAST	SLOW	Fault Display
Icon	  FAST SLOW Press and hold to switch temperature units	 IN/OUT	 FAST	 SLOW	Fault Display



LCD Display Content in Control Panel







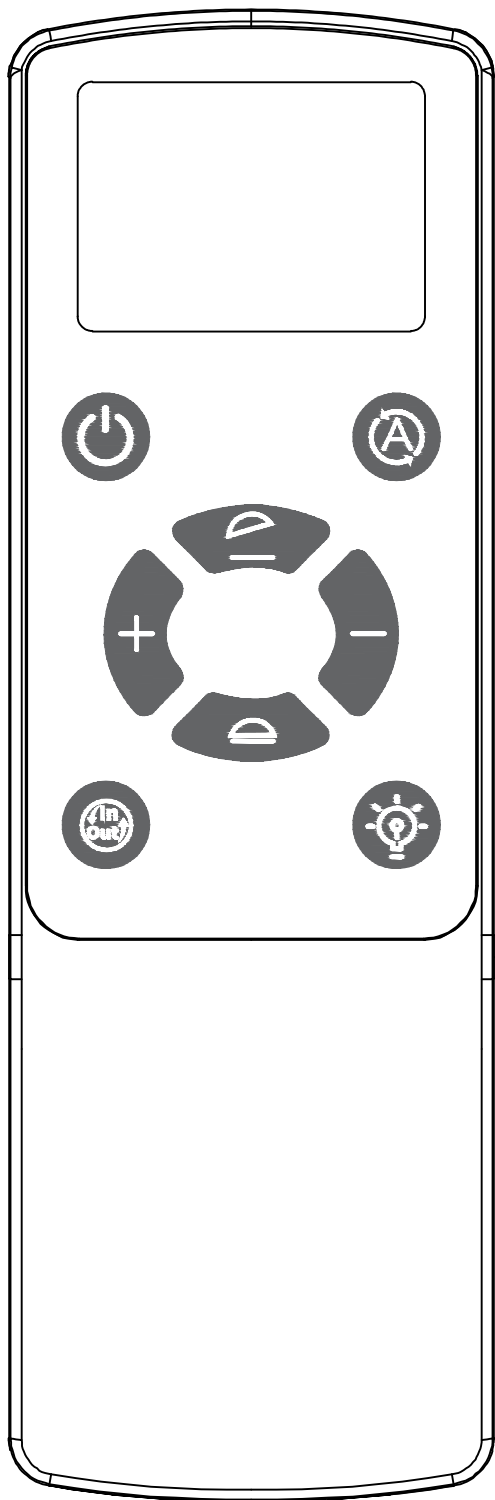

Fault code 	
	Voltage < 9V
	Voltage > 16V

 Startup temperature of the control panel under automatic mode by default: 26°C/79°F!

# How to Use PLUS FAN

## Remote control



Button icon in remote control	Corresponding functions	Remarks
	Power switch	Press it to turn on or press and hold it turn off
	AUTO mode	Adjust the temperature and turn on and off automatically
	Forward and backward rotation of fan	Low noise and comfort during air inlet and out
	LAMP	Remote control of warm white light
	Fan acceleration	Stable acceleration from Gear 0 to 10
	Fan deceleration	Fast deceleration from Gear 10 to 0
	Top cover on	Light transmission during ventilation can prevent mosquitoes
	Top cover off	Sealed design for reducing effect stylish interior



Please turn off the power when leaving the vehicle for a long time!

# How to Use PLUS FAN

## Remote control LCD screen







Remote control LCD icons	Corresponding functions	Button icons of remote control
	Power switch	
	AUTO	
	IN/OUT	
	LAMP	
	FAST	
	SLOW	
	Top cover on	
	Top cover off	
	Switch temperature unit	 
	Fault code	Fault code

Fault code	
	Voltage < 9V
	Voltage > 16V



Short press, unless otherwise specified.

# How to Use PLUS FAN

## Descriptions of special functions: AUTO mode

 <p>Remote control</p>	 <p>Control panel</p>
 <p>Short press to enter AUTO mode</p>	 <p>Short press to enter AUTO mode</p>
<p>Set the temperature to: Adjustable temperature When the indoor temperature is 2 °C higher, the ventilating fan will automatically open the top cover and fan to exhaust air</p>	<p>The default setting temperature is: 26°C/79°F When the indoor temperature is 2°C higher than the default temperature, the ventilating fan will automatically open the top cover and fan to exhaust air outwards</p>
<p>Set the temperature to: Adjustable temperature When the indoor temperature is 2 °C, lower than the set temperature, the ventilating fan will automatically close the top cover and fan</p>	<p>The default setting temperature is: 26°C/79°F When the indoor temperature is 2°C lower than the default temperature, the ventilating fan will automatically close the top cover and the fan</p>
<p>Temperature adjustment methods for remote control setting: Press " + - " in remote control to adjust temperature in AUTO mode</p>	<p>The default setting temperature does not need adjustment</p>

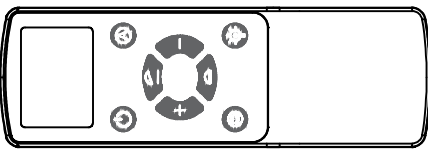
## Descriptions of special functions: Pair code in remote control

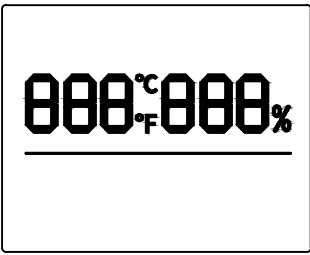
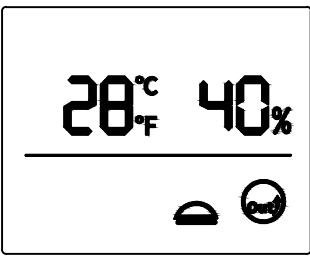
	<p>Code matching in remote control</p>	
<p>Press   button in remote control for 3s within 20s after PLUS FAN is powered on</p>	<p>Enter the code matching state</p>	
<p>After successful code matching, the host buzzer will give out a long sound of "di....."</p>	<p>Success status of matching code</p>	

 The code matching must be completed within 20 s after the ventilating fan unit is powered on (if the matching is not completed, power off and then power on again for matching once again).

# How to Use PLUS FAN

## Manually open/close the top cover

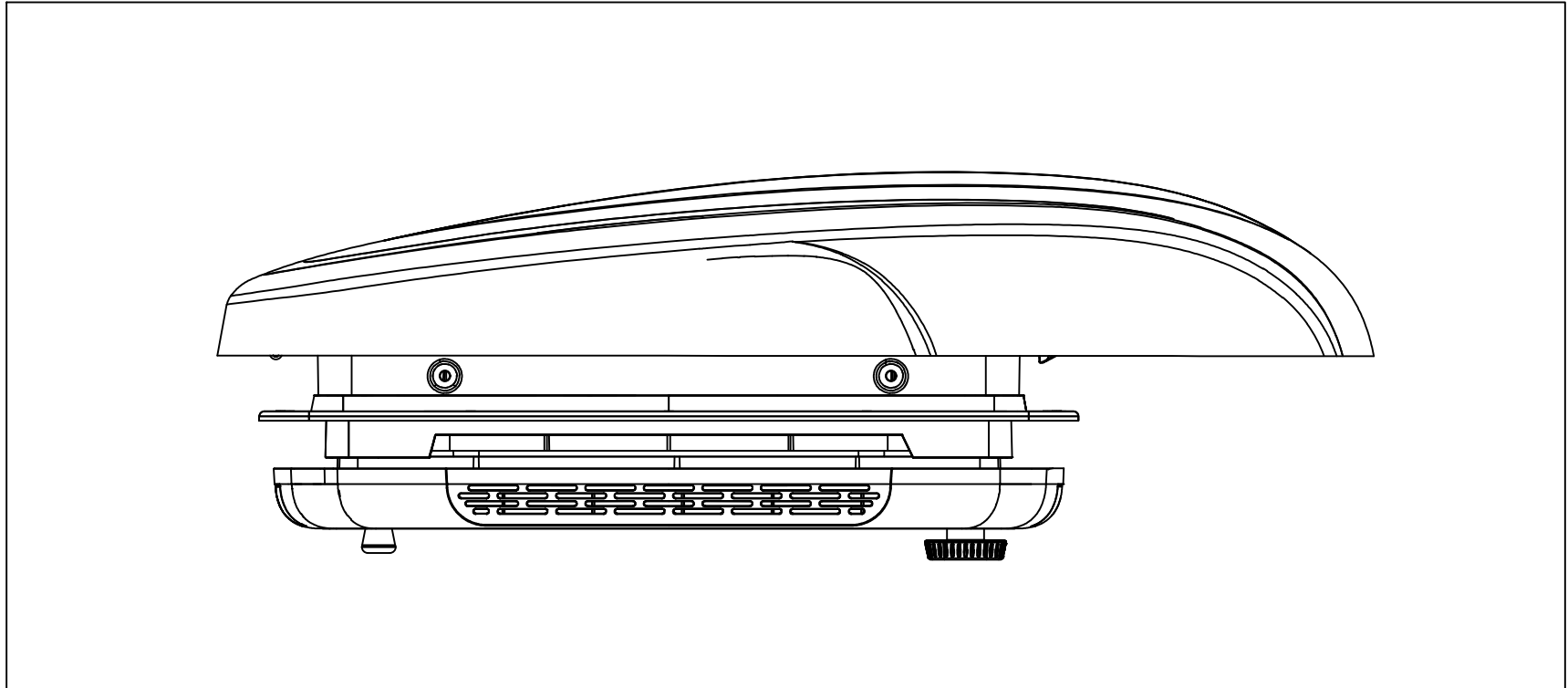

Manually turn the handle to manually open/close the top cover of the ventilating fan

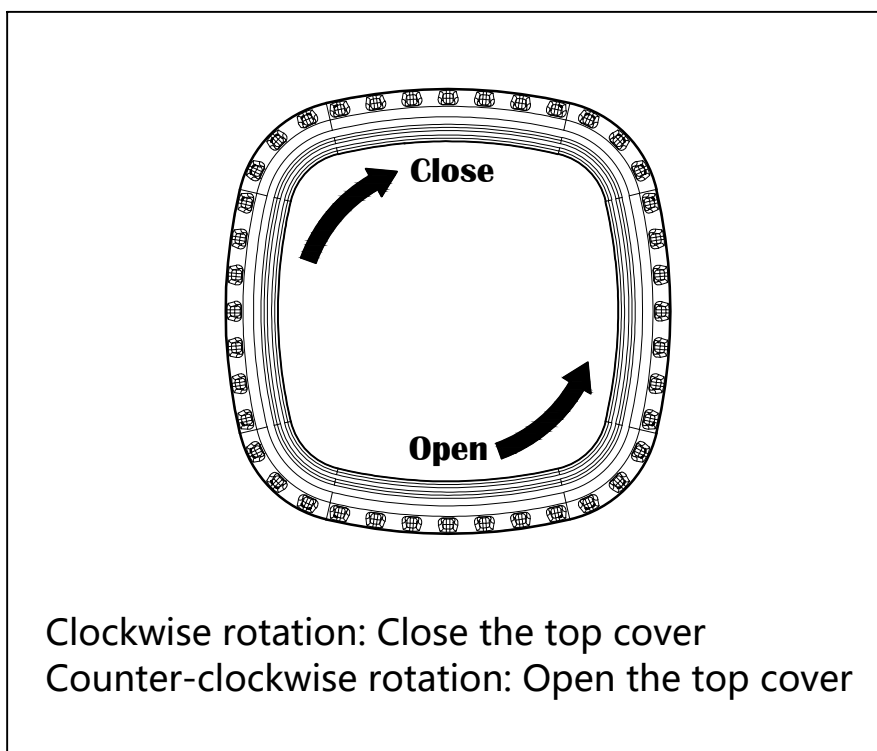

Hand knob

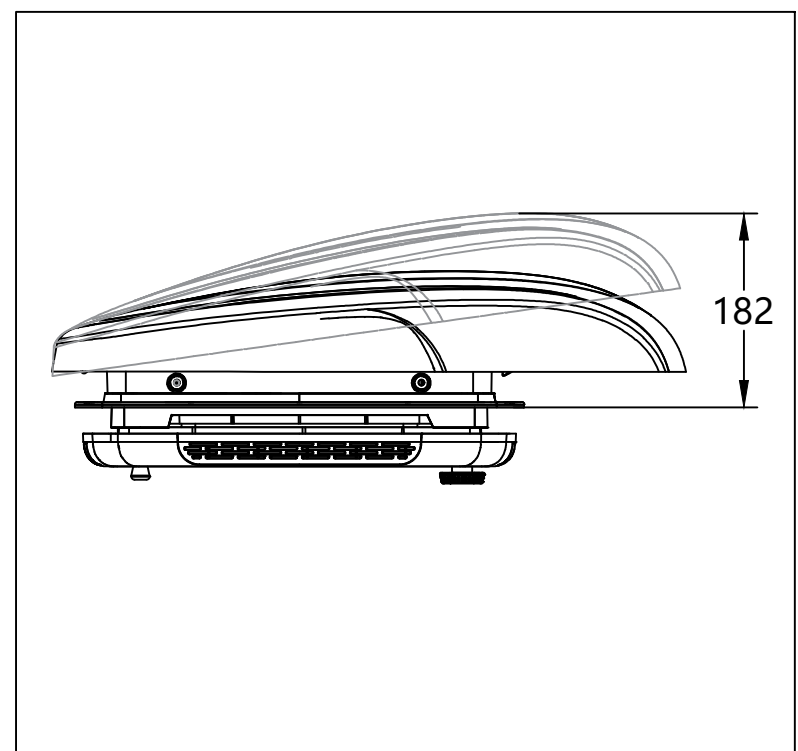

Open max. height



When manually opening the top cover, it is recommended to manually open it after powering off the ventilating fan.



When the top cover is opened or closed manually, the top cover can be opened to the upper limit or closed to stop rotating the handle to prevent internal damage.

# Overall Dimensions

Unit: mm

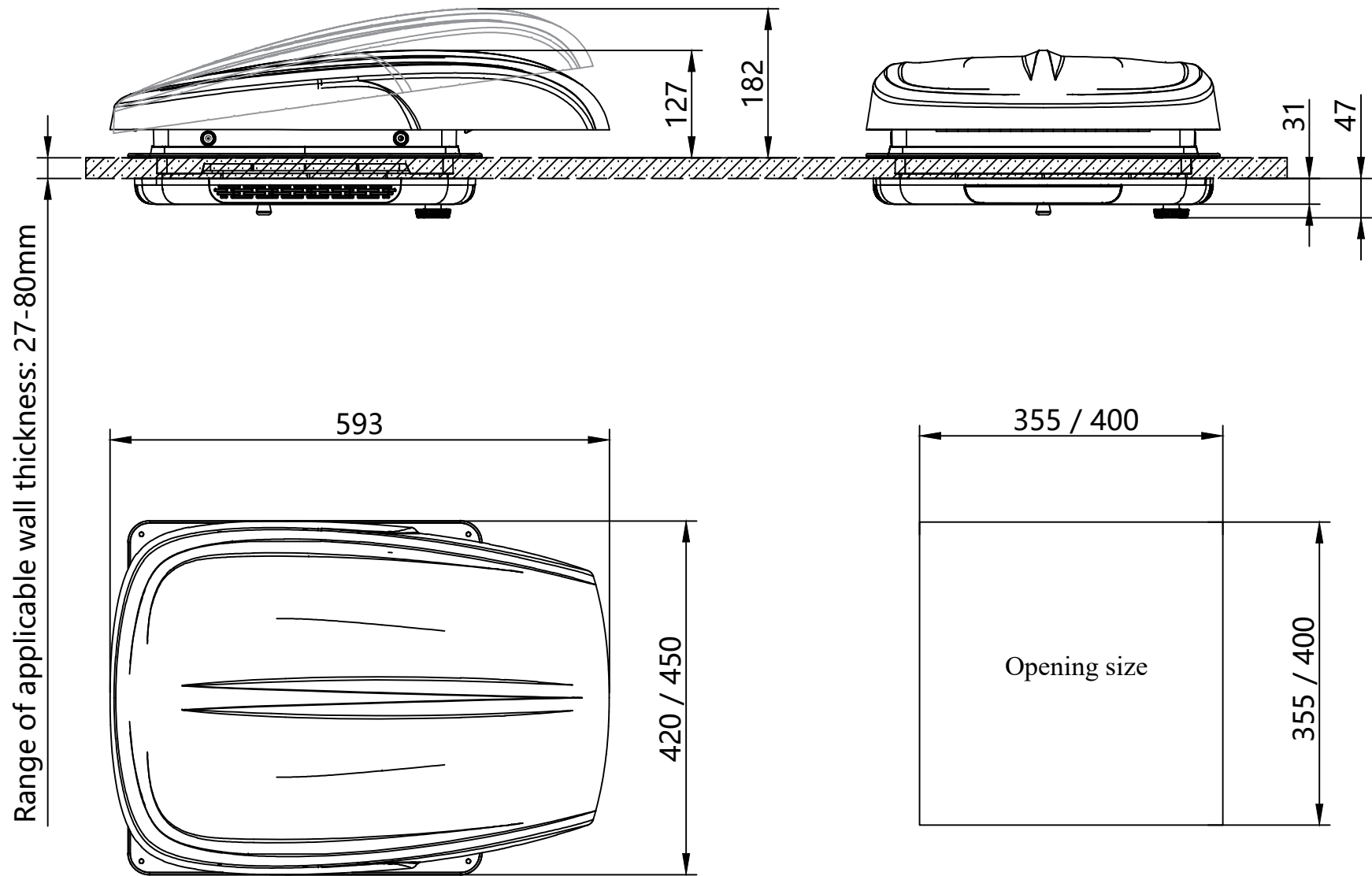

# Packing List

---

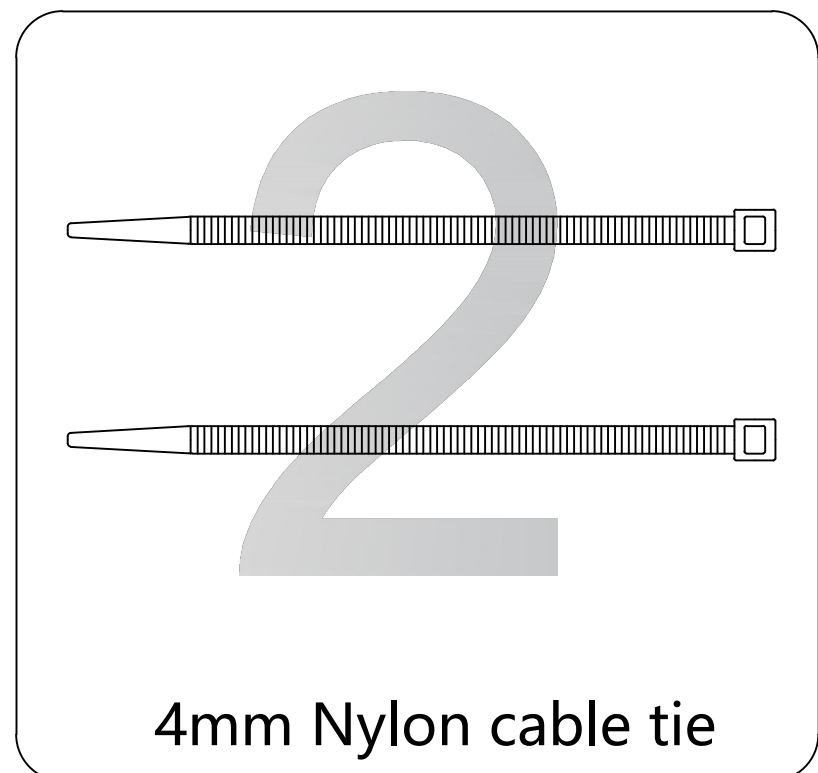
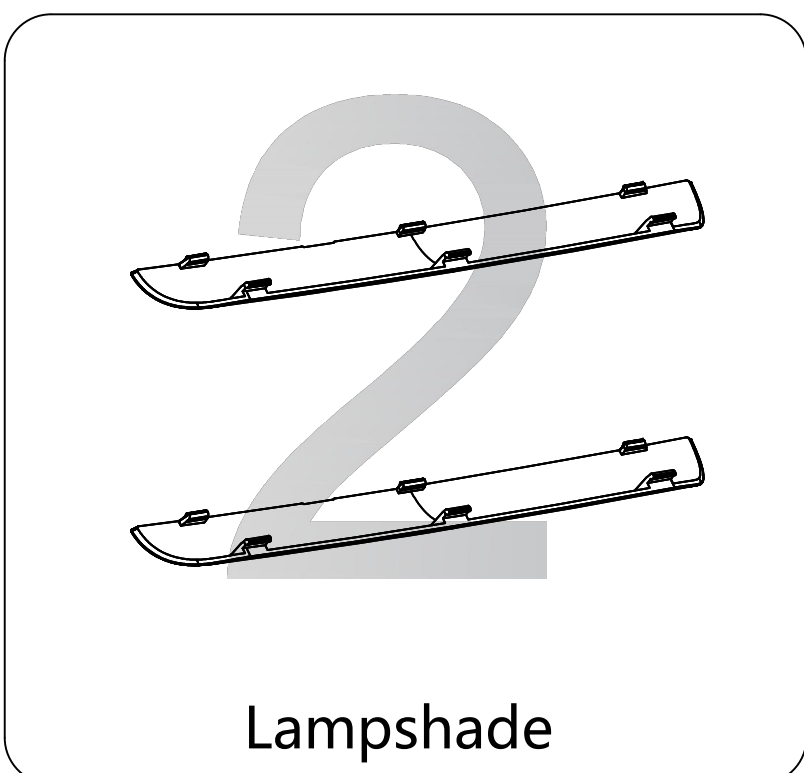
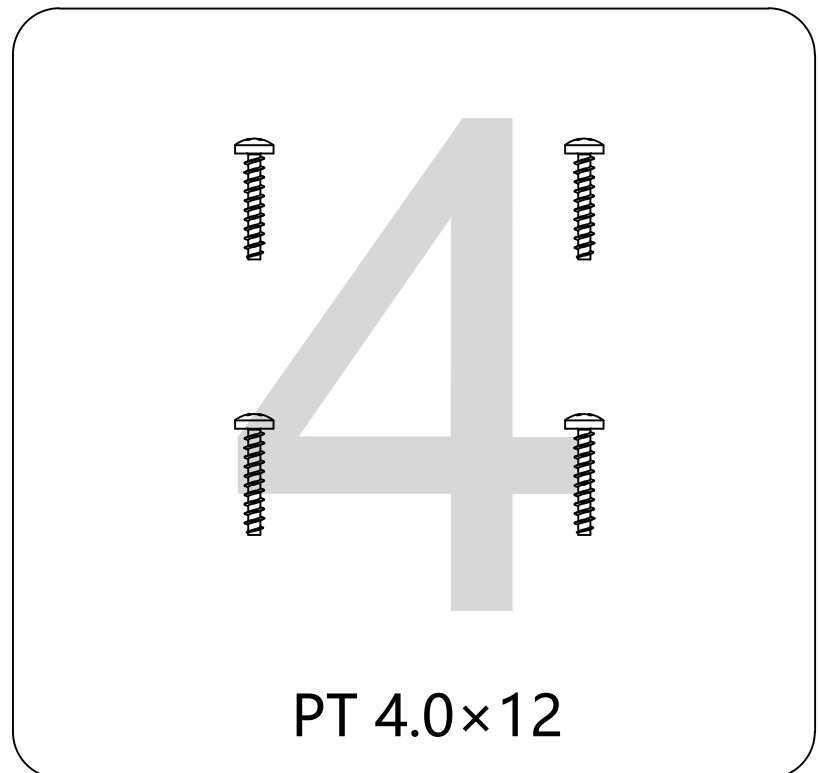
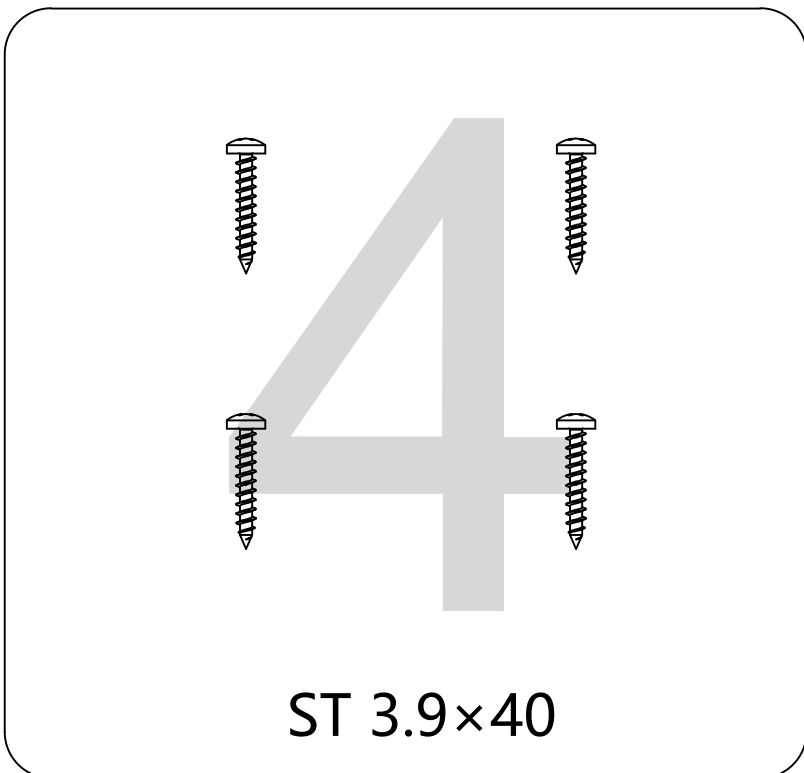
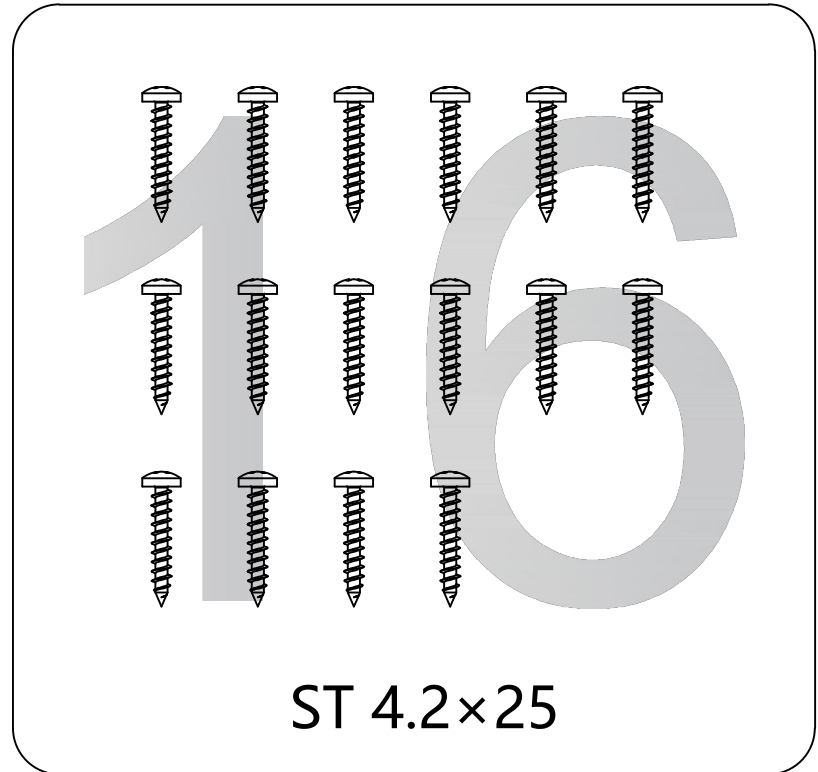

# Packing List

---

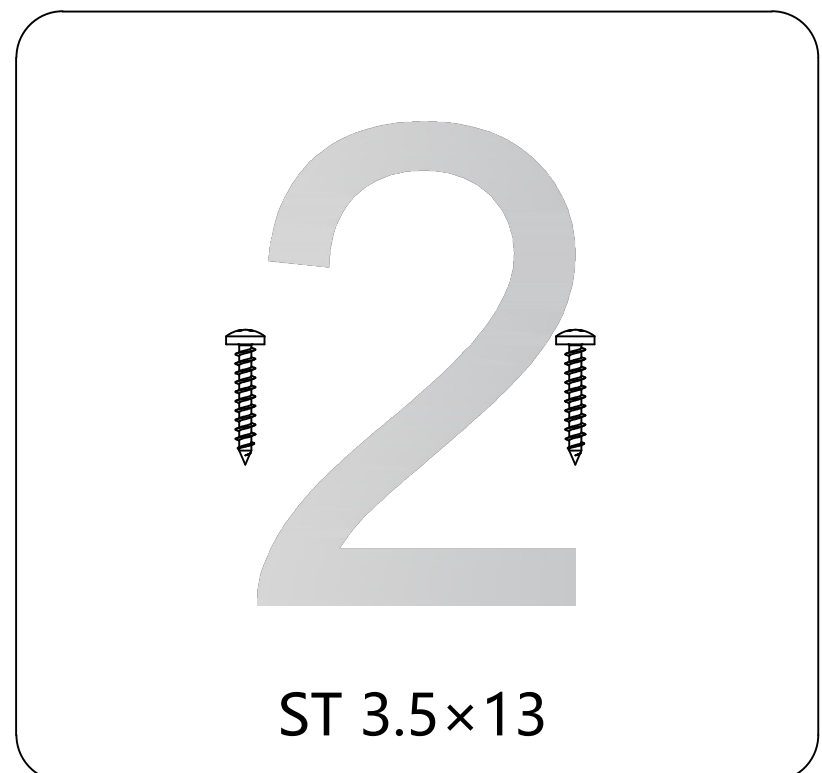
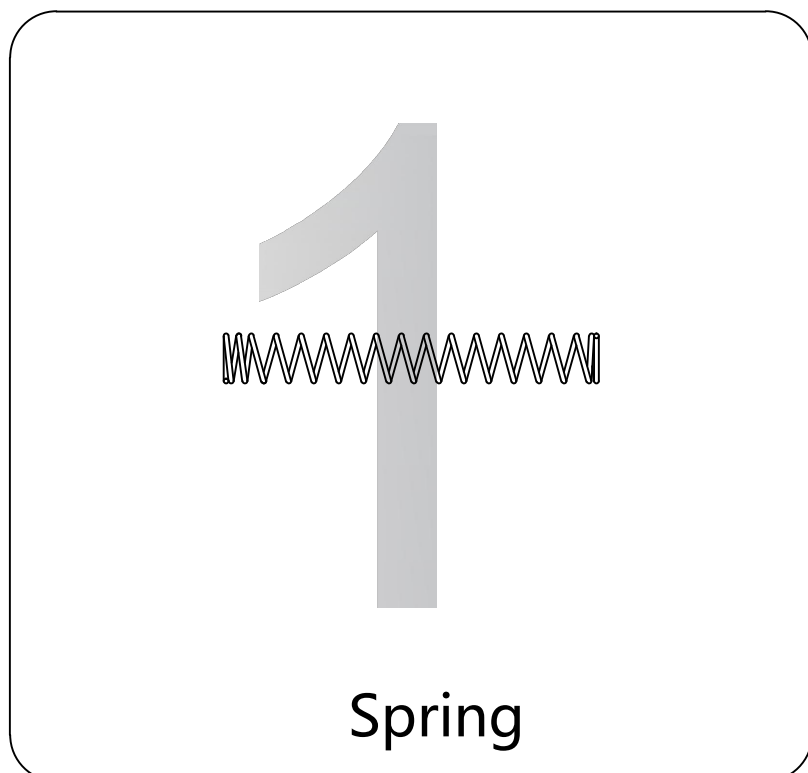
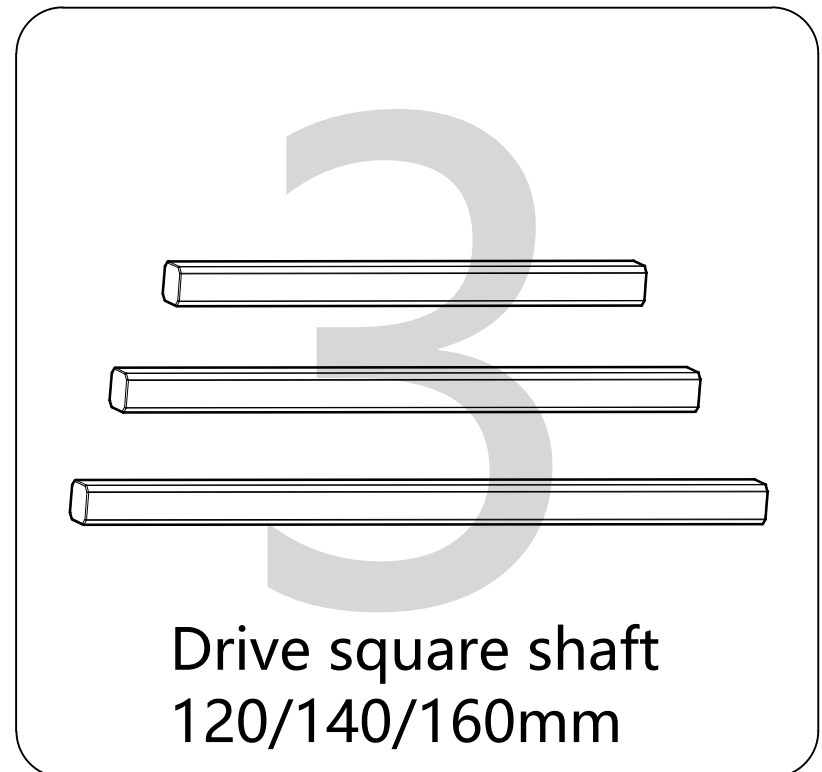
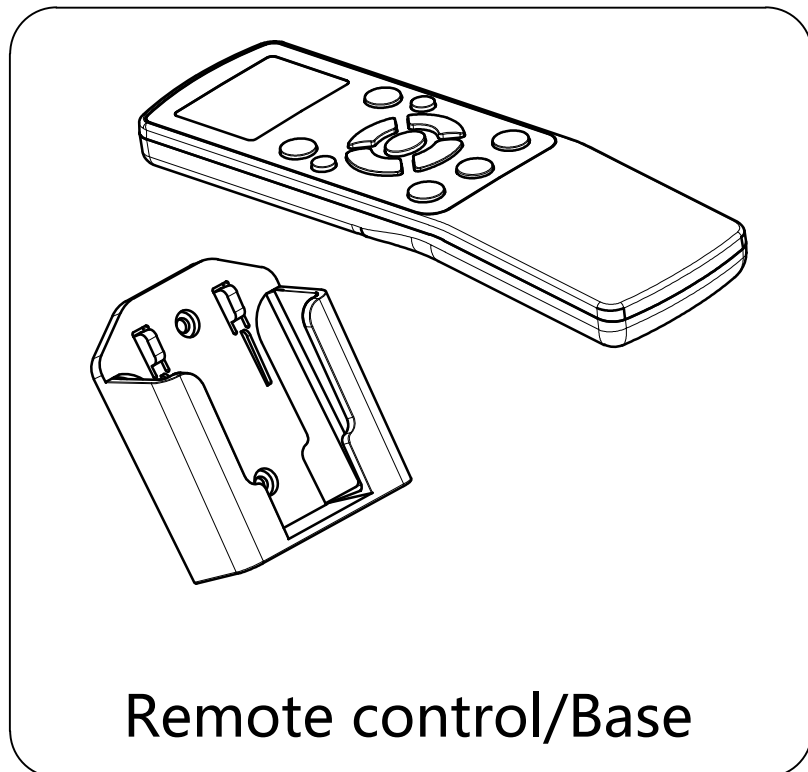

ST 4.2×25 (for fixing the vehicle body fixing plate and the vehicle body)

ST 3.9×40 (for fixing the lower assembly of the interior trim frame to the vehicle body)

PT 4.0×12 (for fixing the upper assembly of the top cover and the fixing plate of the vehicle body)

ST 3.5×13 (for fixing the base of remote controller to the vehicle body)

Drive square shaft: 120mm      suitable wall thickness: 27-47mm

Drive square shaft: 140mm      suitable wall thickness: 48-67mm

Drive square shaft: 160mm      suitable wall thickness: 68-80mm

# Mounting of PLUS Fan

1. Open mounting holes for the ventilating fan on the roof (strong wall with a width  $\geq 30\text{mm}$  is required around the hole to ensure that the self-tap screw can be firmly nailed into that wall) according to the hole size drawing on the [Mounting Dimensions] page. Power cord  $\geq 50\text{mm}$  can be optionally reserved in the opening on the left or right side of the body.

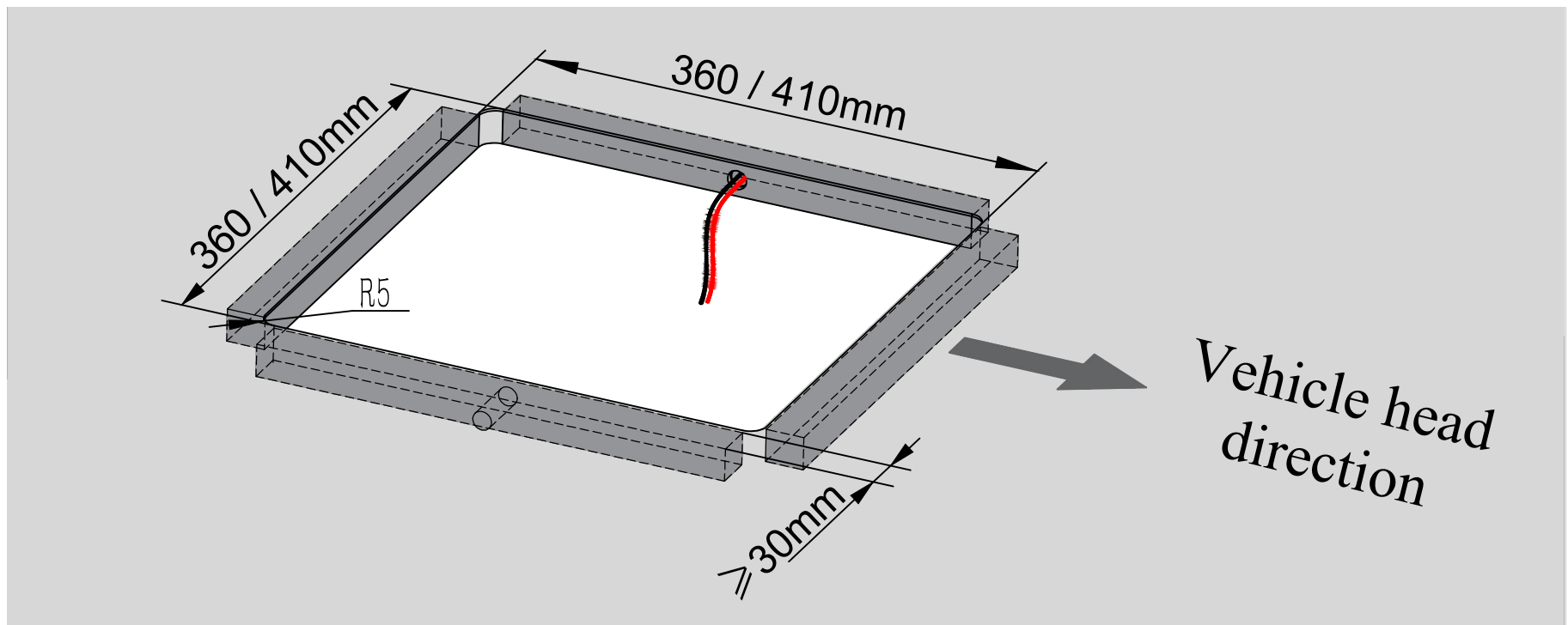

The outlet on the left side of the vehicle body is taken as an example in this manual.

2. Take out the vehicle body fixing plate from the package, and inject sealant (MS type sealant recommended) into the rubber groove of the outer ring of the vehicle body fixing plate frame. The sealant should not be too much, and any excessive glue should be cleaned up with a soft scraper.

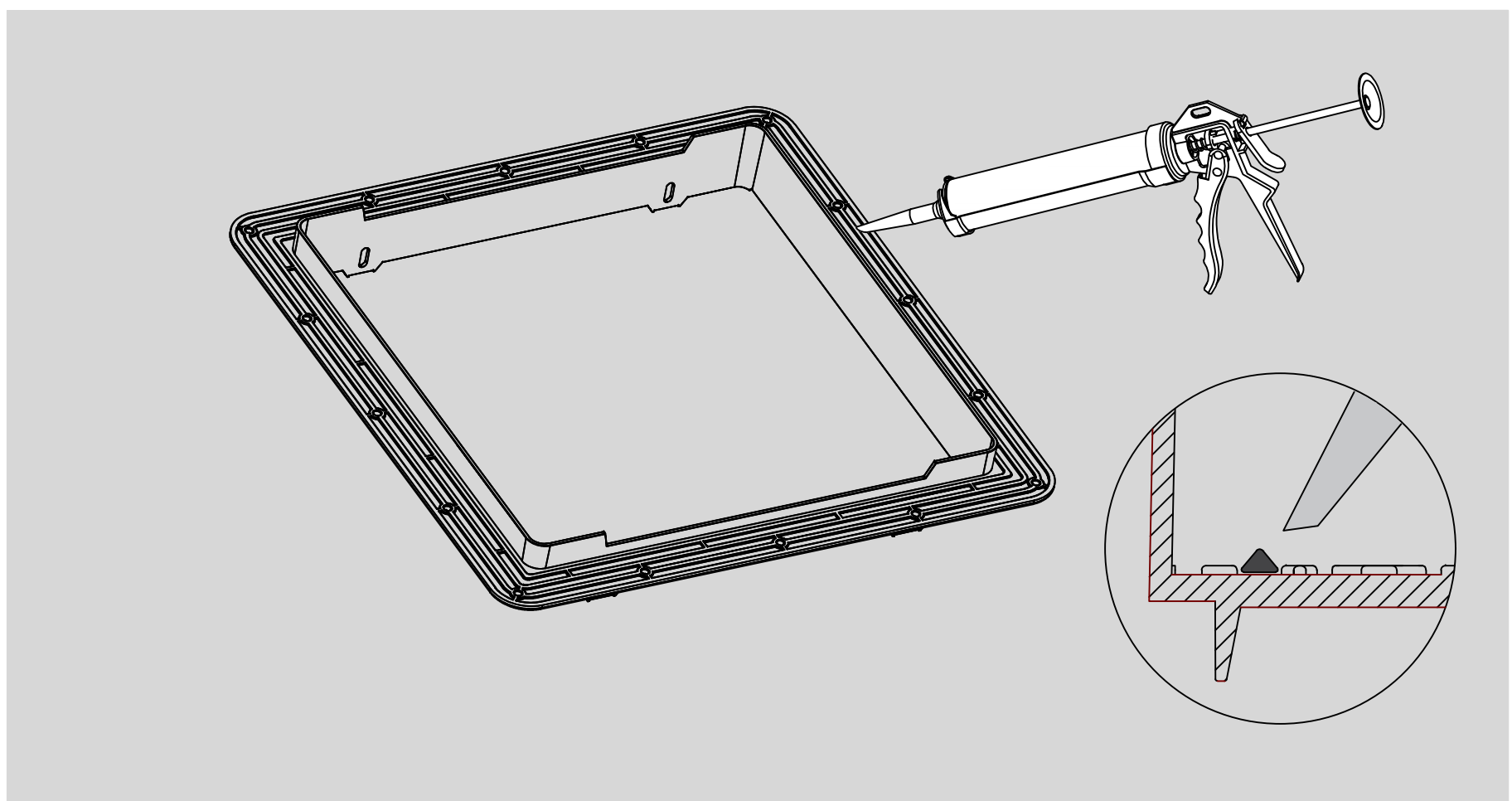

The amount of glue should be even. Do not apply too much glue.

# Mounting of PLUS Fan

3. Fix the body fixing plate on the wall of the motor home with ST4.2×25 cross pan-head screws (16 pcs) outside the body. After fixing the screws, remove excessive glue around the body fixing plate, if any.

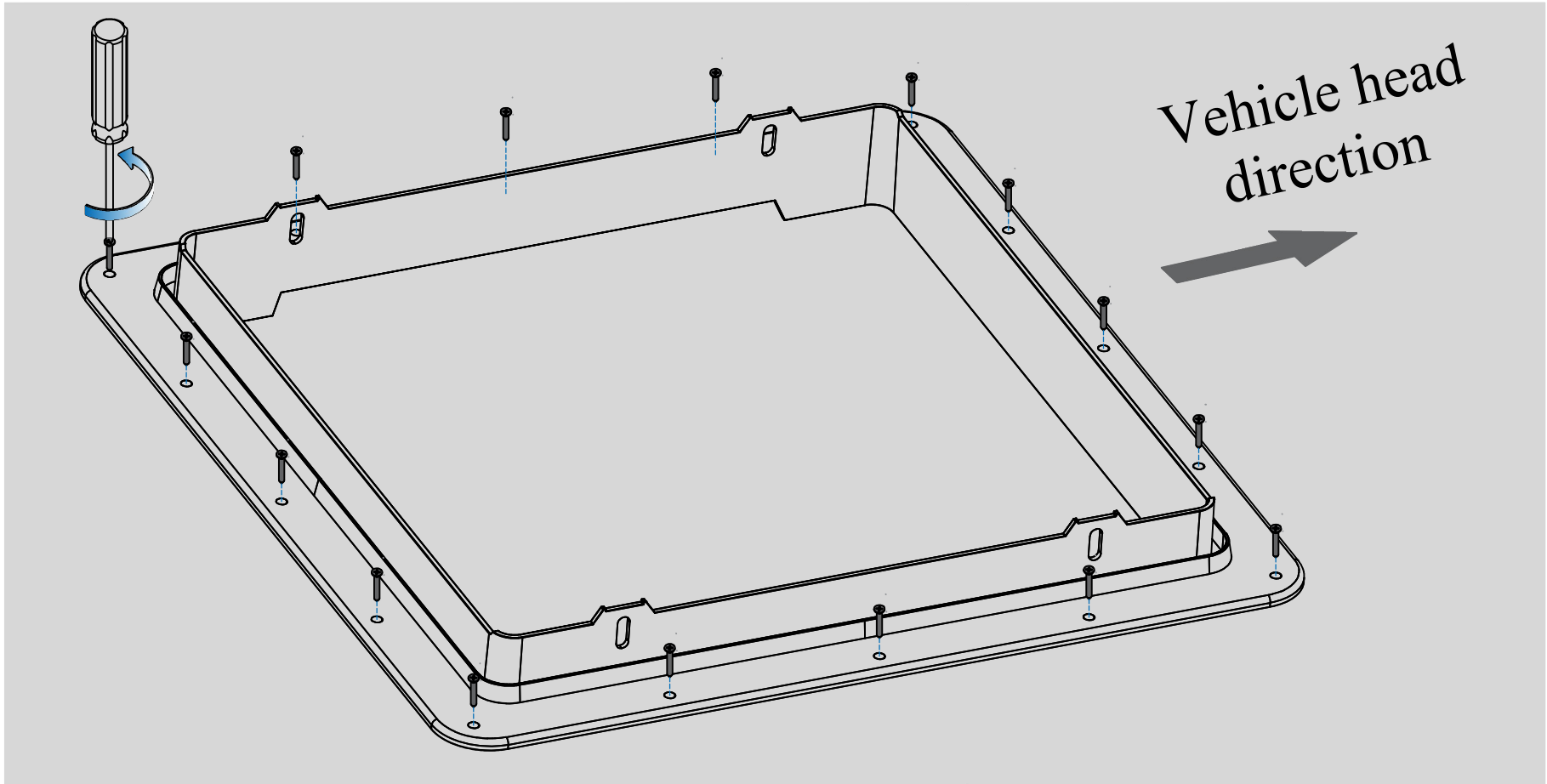

The fixing screw must be fixed firmly.

4. Take out the upper assembly of the top cover of PLUS FAN, align it with the frame of the body fixing plate and insert the upper assembly into the frame. After pressing, fix the upper assembly with the body fixing plate with PT4.0×12 cross pan-head cut-off screws (4 pcs.).

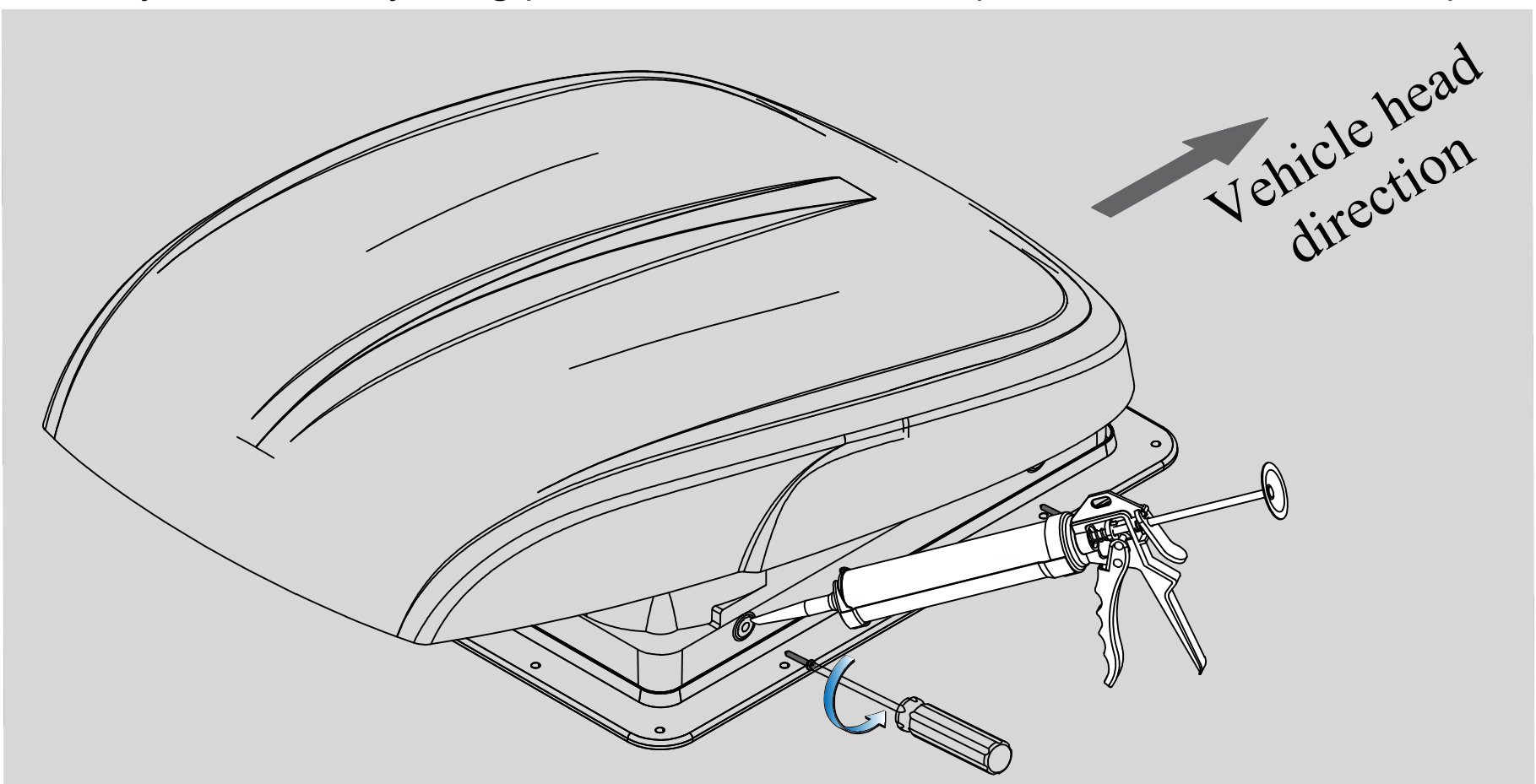

The side fixing screws must be fixed after tightening; otherwise there will be a gap between the adhesive tape between the upper assembly and the body fixing plate, probably causing water leakage. (Recommended screw torque: 0.7 N.m)

# Mounting of PLUS Fan

5. Arrange the outgoing wires of the upper assembly of the top cover of PLUS FAN ventilation fan. There are altogether 3 kinds of wiring terminals (1#/2#/3#female ends).

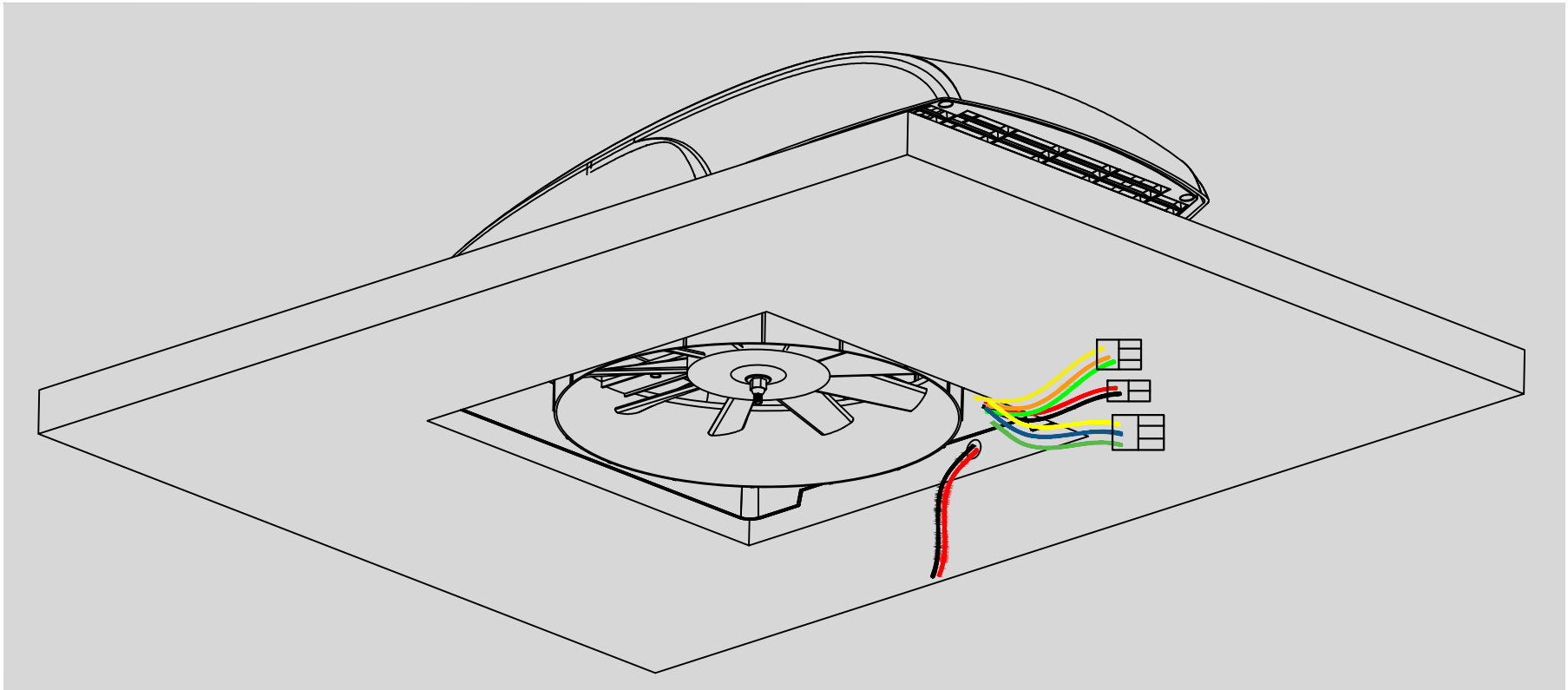

Fan motor wire: (Green, blue and yellow) 3P male end 1#;  
Lifting motor wire: (Red and black) 2P male terminal 2 #,  
(green, orange and yellow) 3P male terminal 3 #;  
Vehicle power cord: (Red and black) bare wire;

6. Arrange the outgoing wires of the lower assembly of the interior trim frame of PLUS FAN ventilating fan, and respectively use 3 kinds of wiring terminals (1#/2#/3#male ends).

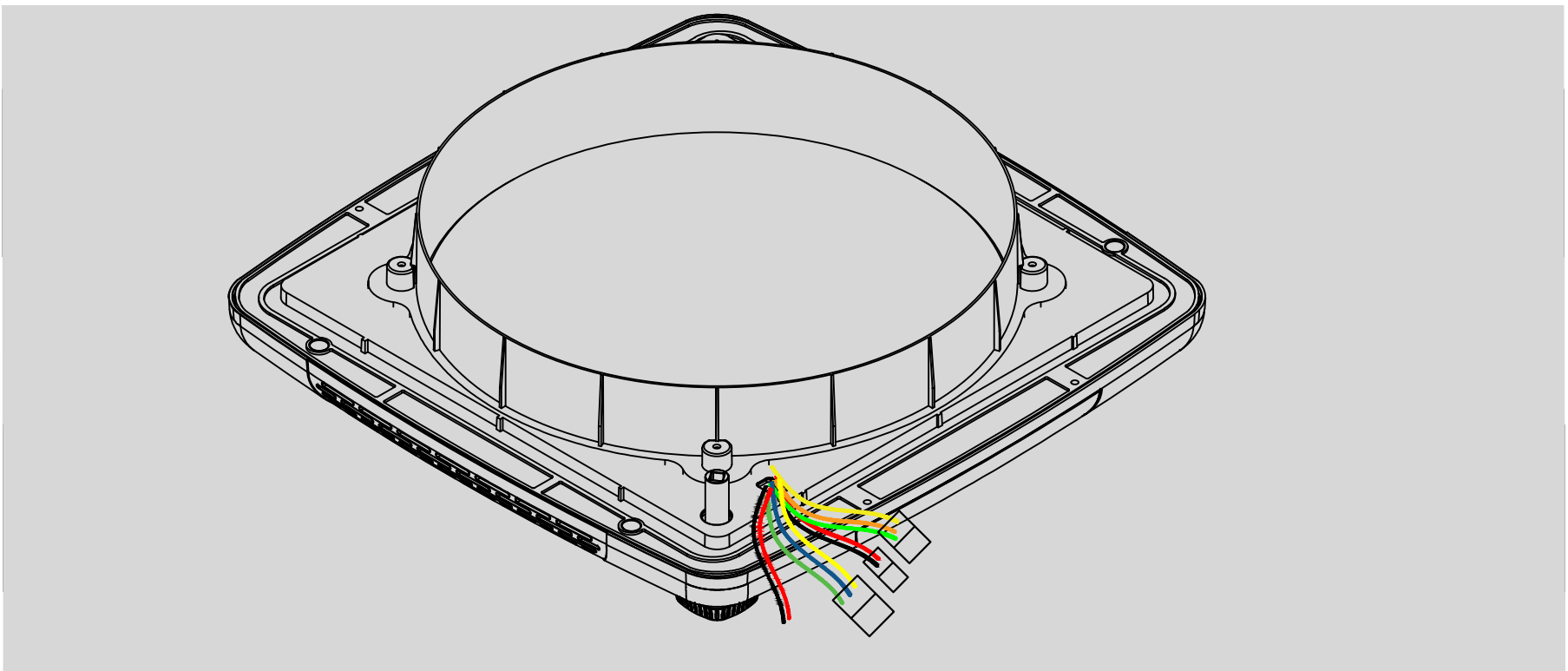

Fan motor wire: (Green, blue and yellow) 3P female end 1#;  
Lifting motor wire: (Red and black) 2P female terminal 2#,  
(green, orange and yellow) 3P female terminal 3#;  
Input power wire of ventilating fan: (Red and black) bare wire;



The harness shall be clean, and free from damage and winding. The terminals shall be firmly connected and the pins shall be free from any damage.

# Mounting of PLUS Fan

7. Connect the harness terminals (3 types) of the upper and lower assemblies of PLUS FAN ventilating fan respectively, and connect the anode and cathode of the power cord.

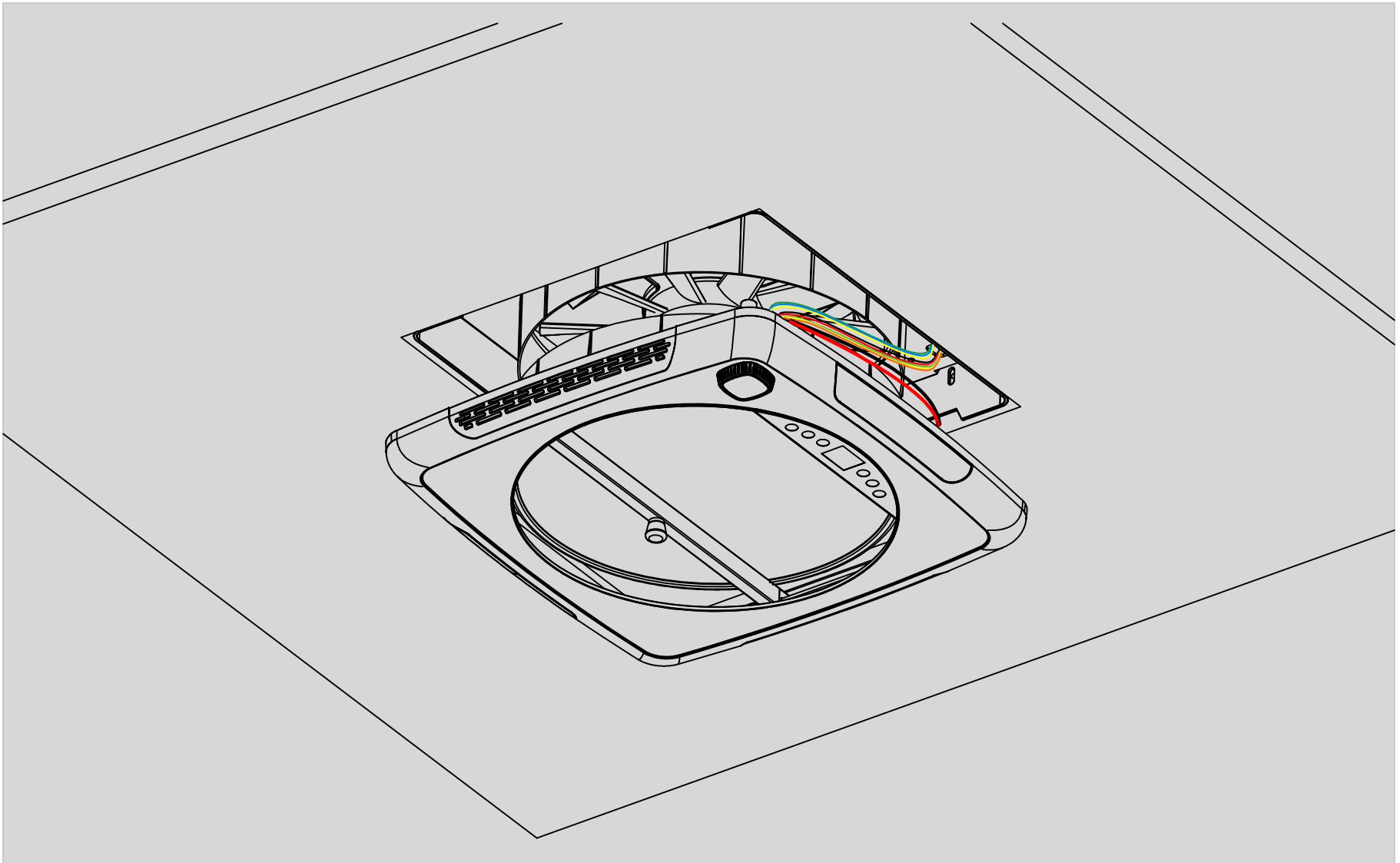

The wiring harness shall be neat, and all terminals shall be connected firmly without any insufficient or omitted connection. The wiring harness shall be aligned in color, and fixed with cable ties after wiring harness arrangement.

8. Place the spring and the transmission square shaft into the manual knob groove of the PLUS FAN in turn.

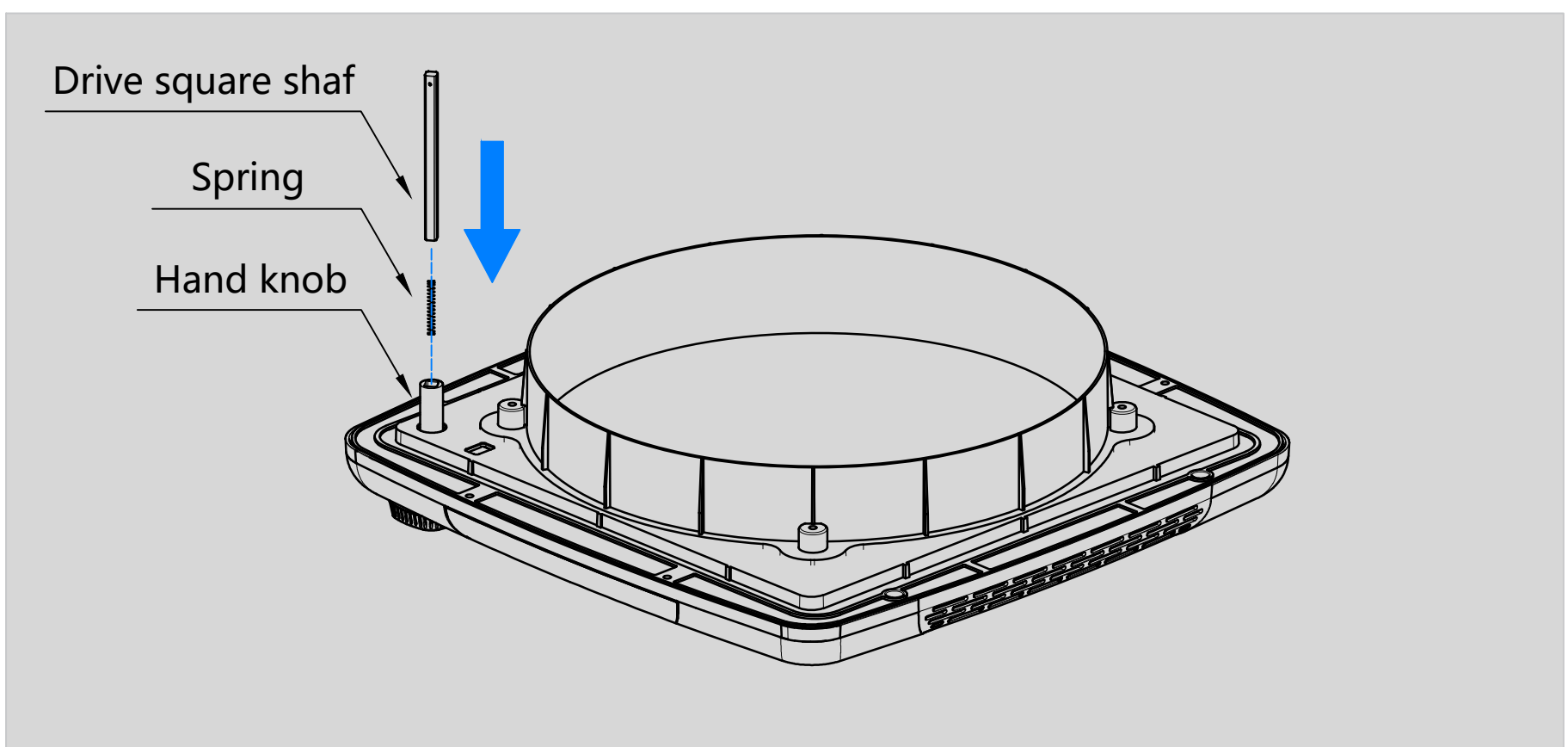

The spring shall be free from damage, the handle shall rotate flexibly without stagnation, and the square shaft shall be clean and free from oil stain and other sundries.

## Mounting of PLUS Fan

9. After arranging the wire harness, align the square shaft with the corresponding position of the upper assembly of the top cover, insert the lower assembly of the interior trim frame of the PLUS FAN, and screw the ST3.9×40 cross pan-head screws (4 pcs) into the corresponding holes in turn.

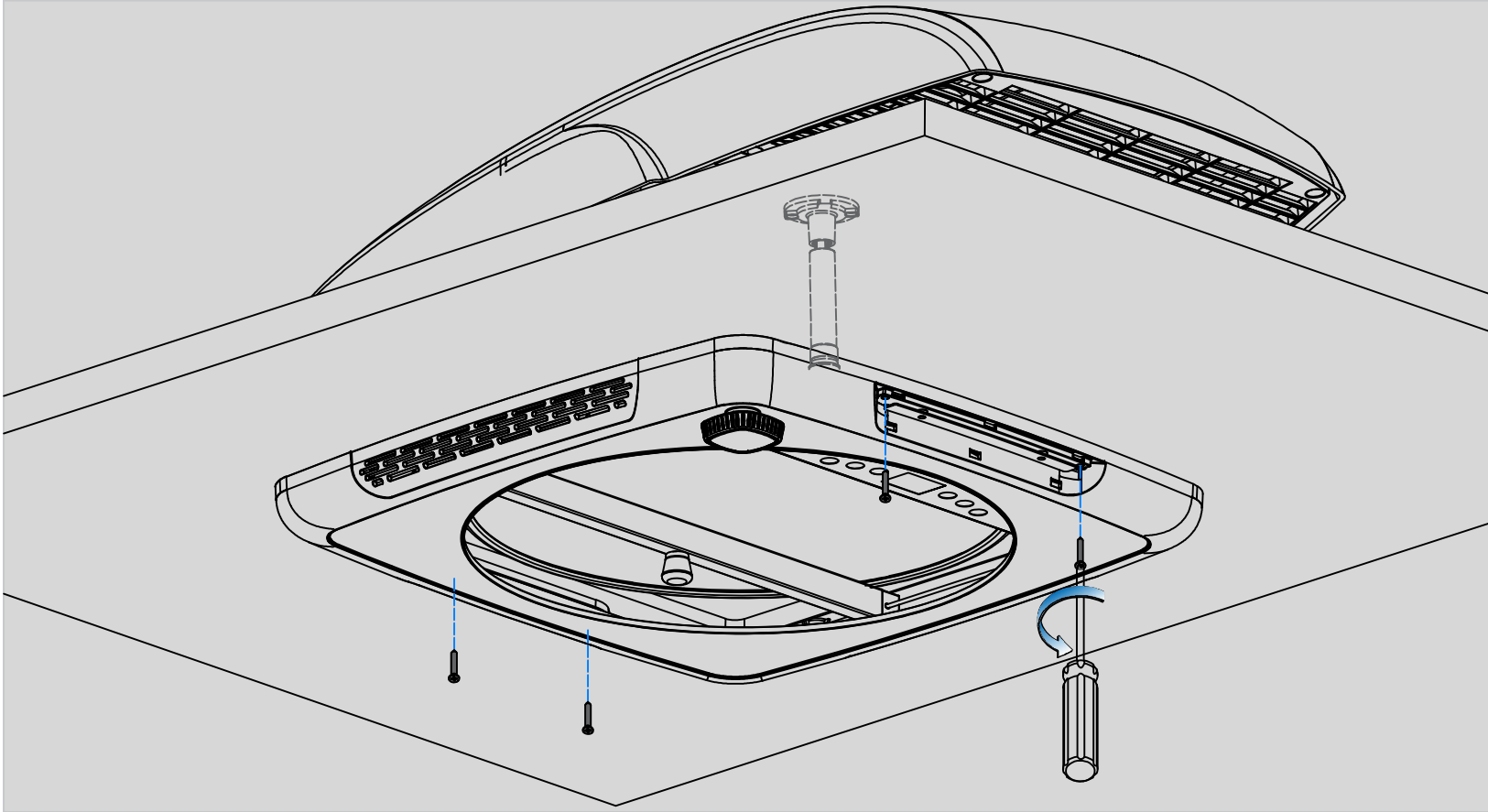

Harness shall be neat and all terminals shall be connected firmly without insufficient or omitted connection. Screws shall be fixed firmly.

10. Insert the lamp covers laterally into the corresponding slots in the lower assembly of the PLUS FAN ventilation fan trim frame.

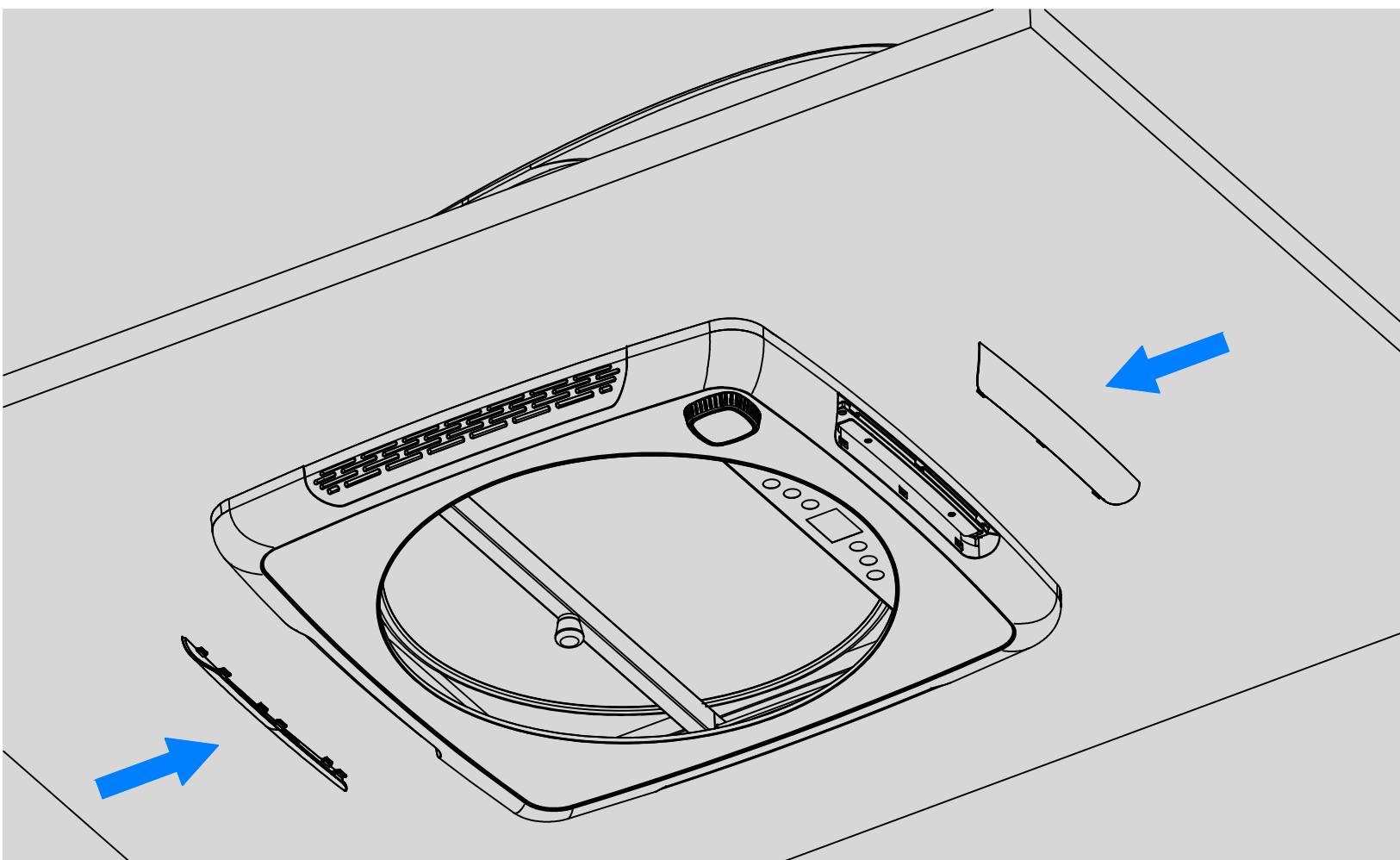

Upon inserting, the lampshade will emit three clicks, indicating that the lampshade has been clamped in place.

# Mounting of PLUS Fan

11. After completing the above steps, clean the debris and dust on the PLUS FAN ventilating fan casing.

Press the power button on the control panel to start using the device.

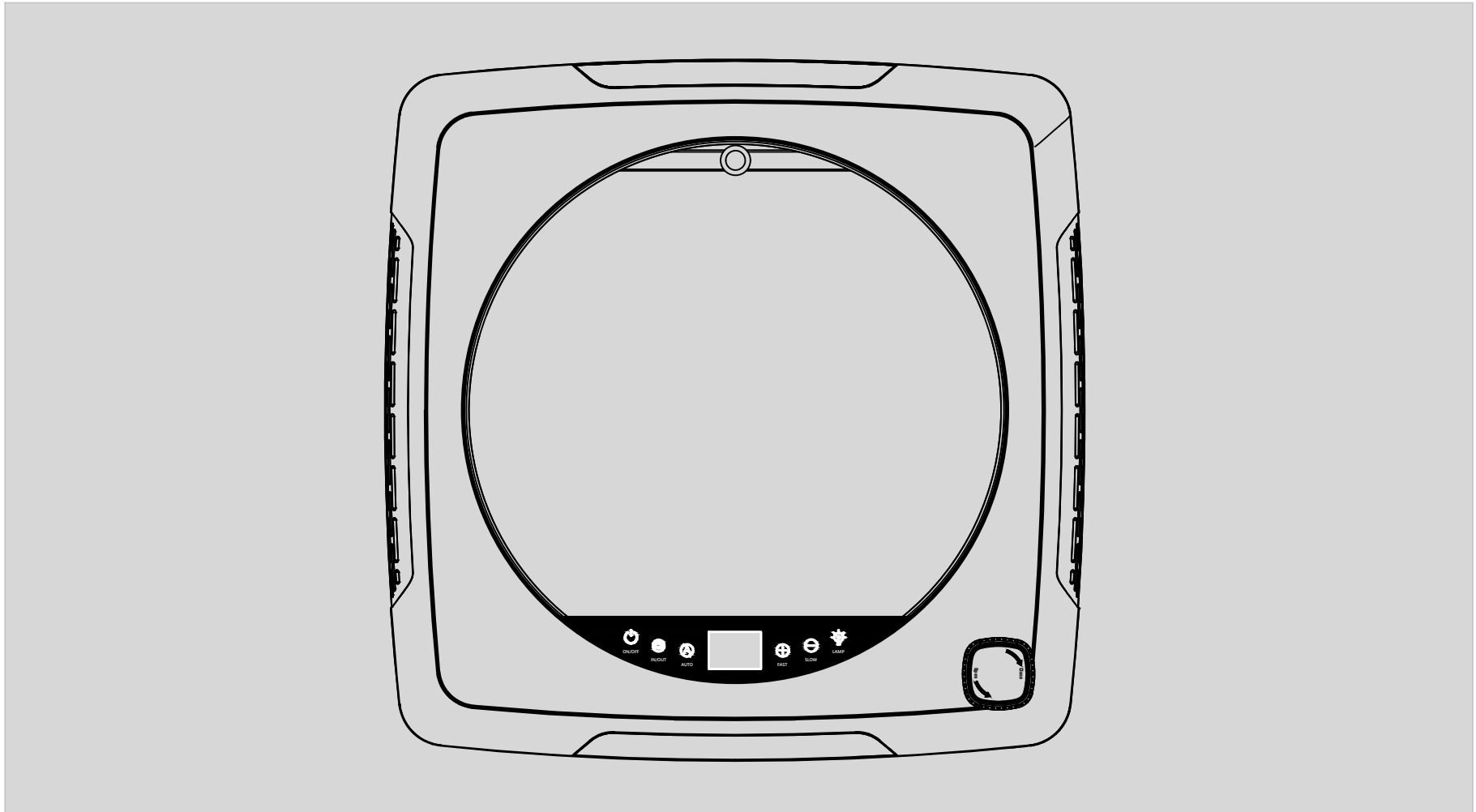

12. After powering on the device for the very first time, try each button on the control panel three times to check the functions of button backlight, lighting lamp, fan acceleration, fan deceleration, open top cover, close top cover, etc.

13. Take the remote control base and 2 ST3.5×13 cross pan-head screws, tear off the double-sided adhesive tape on the back of the remote control base, stick it in the predetermined position and fix it with screws.

Mount a total of 2 AA batteries in the remote control, which can be used after the code is successfully matched.

Please insert the remote control into the base of the remote control when it is not used.

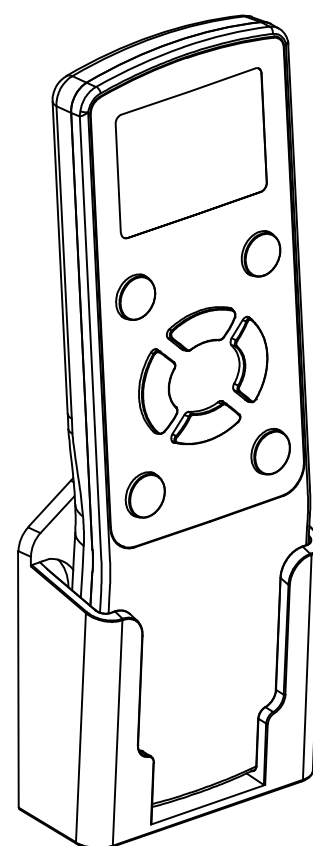
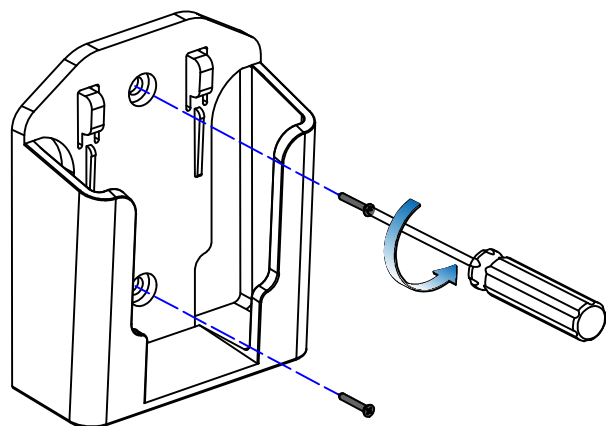

The code matching must be completed within 20 s after the ventilation fan is powered on (otherwise, cut off the power supply and re-match).

# Warranty regulations

---

1. One year warranty is provided for the whole product.

1. Within warranty period, please contact the manufacturer or return it to the sales outlet for repair if the product is defective.

2. Within the warranty period, a fee-based repair and lifetime service will be provided in case of one of the following cases:

1) Failure to present warranty card and valid proof of purchase;

2) Alteration of invoice;

3) Failure and damage caused by accidental factors and improper use;

4) Failure and damage caused by self-repair without authorization;

5) Damage caused by using a power supply or voltage other than specified;

6) Products that have been repaired and continue to be used beyond the validity period of warranty;

4. The validity period of warranty is from the date of receiving. During the validity period of warranty, consumers can apply for repairs, returns and exchanges with the invoice and the warranty card.



# Warranty card

---

Product name: \_\_\_\_\_  
Product model: \_\_\_\_\_  
Serial number: \_\_\_\_\_  
Date of manufacture: \_\_\_\_\_  
Customer name: \_\_\_\_\_ Contact number: \_\_\_\_\_  
Customer address: \_\_\_\_\_

---

Warranty content: \_\_\_\_\_  
After sales: \_\_\_\_\_  
Customer signature: \_\_\_\_\_  Satisfied  Dissatisfied

---

Warranty content: \_\_\_\_\_  
After sales: \_\_\_\_\_  
Customer signature: \_\_\_\_\_  Satisfied  Dissatisfied

---

Warranty content: \_\_\_\_\_  
After sales: \_\_\_\_\_  
Customer signature: \_\_\_\_\_  Satisfied  Dissatisfied